

Manual 828 E



Contents

Monark Exercise AB	4
Product Information	5
<i>Facts</i>	5
<i>PC software</i>	5
<i>Serial number.....</i>	5
Operating Instruction.....	6
<i>Workload adjustment</i>	6
<i>Power measurement.....</i>	6
<i>Cycle adjustments.....</i>	6
<i>Calories.....</i>	6
<i>Meter instructions.....</i>	7
<i>Heart rate</i>	7
<i>Scale - zero adjustment</i>	8
<i>Calibration.....</i>	8
Troubleshooting guide.....	9
Service.....	10
<i>Warning.....</i>	10
<i>Warranty</i>	10
<i>Service check and Maintenance</i>	10
<i>Batteries.....</i>	11
<i>Flywheel bearing.....</i>	11
<i>Crank bearing</i>	11
<i>Transportation</i>	11
<i>Replacement of brake belt</i>	11
<i>Brake belt contact surface</i>	11
<i>Chain 1/2" x 1/8"</i>	12
<i>Freewheel sprocket.....</i>	13
Spare parts list	14

Important

Read the manual carefully before using the cycle and save it for future use.

Monark Exercise AB

Monark has 100 years' experience of bicycle production. The Monark tradition has yielded know-how, experience, and a real feel for the product and quality. Since the early 1900s, Monark's cycles have been living proof of precision, reliability, strength and service. Those are the reasons why we are now the world leader in cycle ergometers and the market leader in Scandinavia in transport cycles.

We manufacture, develop and market ergometers and exercise bikes, transport bikes and specialized bicycles. Our largest customer groups are within health care, sports medicine, public authorities, industry and postal services.

For more information: <http://www.monarkexercise.se>



Product Information

Congratulations on your new Ergometer!

The adjustable brake system and the force can be set and read Kiloponds (kp) and Newton (N). The actual brake power is showed in Watts on the electronic meter. The energy that a person has to develop over time to overcome this braking power, can thereby be calculated. The energy is usually expressed in kJ (kilojoules) or kcal (kilocalories).

Ergomedic 828 E is also equipped with an electronic meter that displays pedal revolutions per minute (RPM), heart rate in beats per minute (HR), time in minutes and seconds (TIME), speed in km per hour / miles per hour (SPEED) and the distance travelled in km / miles (DISTANCE). In addition braking power can be set, giving a reading of calorie consumption (CAL) and power in watts (WATT). The watt level depends on pedalling speed, it can be fine tuned by increasing or decreasing the speed or pedal rpm.

Each 828 E is calibrated at the factory. This means that you can begin to use the ergometer directly after assembly. However, if the user wishes to verify the scale, please read the instruction for "Calibration" in this manual.

NOTE!

Use of the product may involve considerable physical stress. It is therefore recommended that people who are not accustomed to cardiovascular exercise or who do not feel completely healthy, should consult a physician for advice.

Facts

- Large, well-balanced flywheel 20 kg (44 lbs)
- Pendulum scale, easy to calibrate
- Adjustable saddle and handlebar
- Stable frame, solid steel tube
- Powder painted
- Wheels for easy transport
- Electronic meter with heart rate

Width

517 mm (20 1/3") at handlebar

640 mm (25") at support tubes

Length

1120 mm (44")

Height

945-1295 mm (37-51") at handlebar

780-1105 mm (31-43 1/2") at seat

Weight

52 kg (114 2/3 lbs)

Max user weight 250 kg (551 lbs)

Included

Chest belt

PC software

If you need a pc software to do exercise tests on the bike, our software is available for free download from our website: www.monarkexercise.se.

Serial number

The serial number is placed according to *Fig: Serial number*.

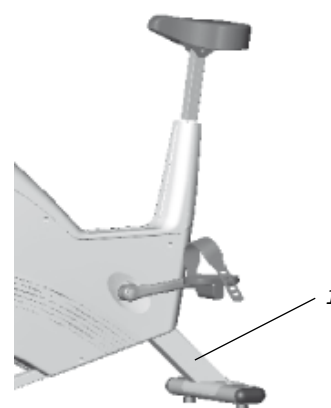

Fig: Serial number (1)

Operating Instruction

Workload adjustment

When pedalling the energy is stored in the flywheel. The flywheel is then braked by means of a brake belt/cord which runs around the flywheel. Changing of the braking effect occurs either through different pedalling speed, or by using the work load knob (1) to increase or decrease the brake band tension on the brake wheel. See *Fig: Workload adjustment*.

Power measurement

The cycle is designed to measure the power on the flywheel, because tests/protocols are made for it (for example Åstand's and YMCA).

Cycle adjustments

Seat height should be adjusted to a comfortable position. The appropriate height is to have the knee slightly bent when the sole of the foot is centred over the pedal axle with the pedal in the bottom position. To adjust the seat height loosen the lever (1) on the seat tube. See *Fig: Adjustments*.

The handlebar setting should be in a comfortable position when cycling. During longer exercise sessions it is recommended to occasionally change handlebar position. To adjust the handlebar, loosen the quick release lever (2). See *Fig: Adjustments*.

NOTE! The handlebar stem should be inserted into the frame tube at least 3 inches (about 8 cm). This measure is marked with "MAX" on the stem (3).

Calories

There have been different theories on how to calculate this, since it depends on several factors and this means that it can only be seen as an estimate.

We have chosen the following formula that we think complies with the results given for a standard cycle position.

As a standard calculation when we display calories on our calibrated bikes we use: 1 minute with 100W gives 7 kcal.

It is easy to convert watts to calories if it was on the flywheel (the formula is $1W=0,2388 \times 10^{-3}$ kcal/s with four decimals), but when you normally show calories you want to show the total amount of calories your body has used during your training, not only the calories "burnt" on the flywheel.

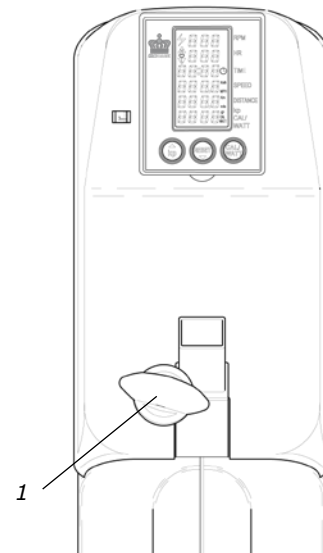

Fig: Workload device (1)

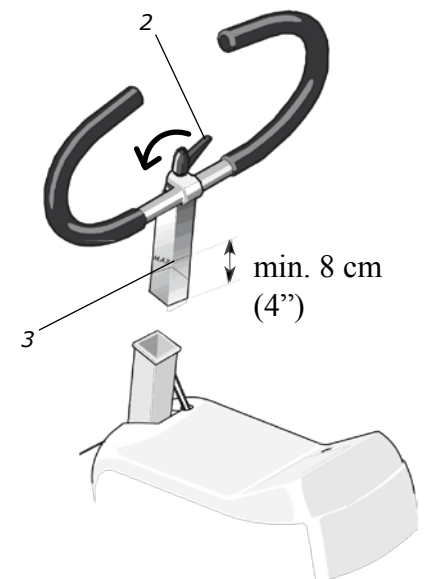
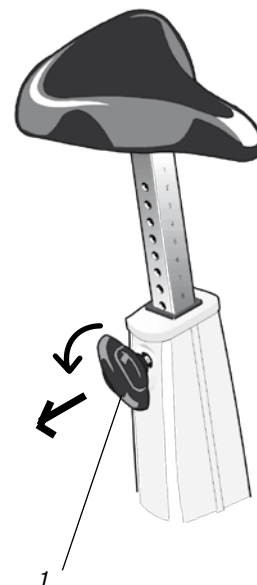

Fig: Adjustments
1) Locking knob, saddle
2) Locking handle, handlebar
3) Inserted min. 3"



Meter instructions

Display		
Pedal revolution (RPM)	0 - 250	rev./min.
HR	50 - 240	bpm
TIME	0:00-99:59	min:sec
SPEED	0 - 99	km/h
DISTANCE	0.0 - 99.9	km
FORCE	0.0 - 7.0	kp
Calories (CAL)	0 - 999	kcal
WATT	0 - 7 x rpm	watt

Batteries: 1.5 V x 2, AA
 Storing temperature: -10°C - +60°C
 Operating temperature: 0°C - 50°C

Press any key or move the pedal gives a signal to the meter that activates all functions. At the display for heart rate (HR) a heart symbol is lit which means that the meter is trying to find a pulse signal from an external source, chestbelt with electrodes, Art. No: 9339-98. If the meter cannot find such a signal the HR function is automatically turned off after 30 seconds. When the function is turned off the heart symbol is not lit any more. The heart rate function can be turned on again by pressing any key.

The timer starts automatically when pedals are moved. Meter values for time (TIME), distance (DISTANCE) and calories (CAL) can be set to zero by pressing the RESET button for more than two seconds. To get correct readings for calories and watts, the kp-value on the electronic meter has to be set to the same value as the pendulum, or the kp-window shown to the left of the electronic meter.

Example:

The pendulum and the kp-window is showing 2 kp. Press the kp button to the left on the meter. The lower display window is now showing figures in kp. Increase or decrease in steps of 0.1 kp by pressing the kp button - (arrow up) or the RESET button - (arrow down) until the reading corresponds with the actual or desired kp-values on the pendulum scale or in the kp-window. After that press the CAL/WATT button to either show the CAL or WATT figures. At further press on the CAL / WATT-button the display toggles between calories and watts. The watt reading in the display is depending on the pedalling speed. The watts can accordingly be adjusted by increasing or decreasing the pedalling speed. Calories are calculated all the time.

Do not expose the meter to direct sunlight or extremely high temperature. Do not use any dissolvents when cleaning. Use only dry cloth.

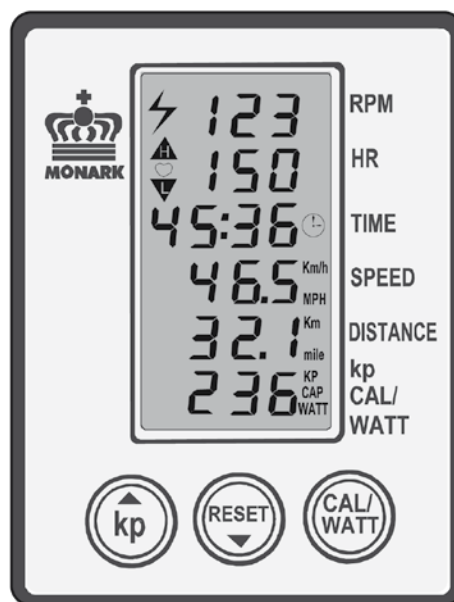
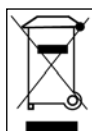

Heart rate

A person's heart rate can be measured with a chest belt that senses the electronic output of the heart. The chest belt is standard equipment.

Fuss-free HR measurement requires that the belt is correctly placed. When it is correctly fitted the logo on the belt will be central and readable, outward and upright, by another person. Before putting on the belt, clean the skin where the belt is to be placed. The chest belt should be secured at a comfortable tension around the mid section, just below the breast muscle, see *Fig: Placement of the chest belt*. Moisten the electrodes before use, see *Fig: Electrodes on the back of the chest belt*. To make contact with the HR receiver on the bike, the distance should not be more than 100 cm / 39 1/3". It is especially important when first used to identify the chest belt with the sensor, by standing close to get the HR (maximum 60 cm / 23 2/3").

NOTE! Electromagnetic waves can interfere with the telemetry system. Cellular phones are not allowed to be used near the bike during test.

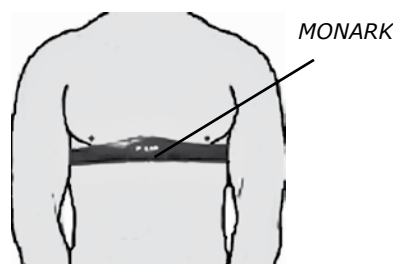

Fig: Placement of the chest belt

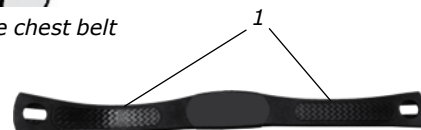

Fig: Electrodes on the back of the chest belt (1)

Scale - zero adjustment

Check that the pendulum will hang in vertical position.

Scale board:

Check that the index on the pendulum (2) weigh is aligned with the index at the 0-position on the scale board. If adjustment is necessary, first loosen the locknut (1) and then change the position of the scale board. Tighten the locknut after the adjustment. See *Fig: Zero adjustment*.

Kp-scale:

At the same time, check that the kilopond-scale (5) to the left of the meter, shows 0 in line with the index. To adjust the kp-scale loosen the lock screw for scale indicator (9). Tighten the screw firmly after the adjustment. See *Fig: Calibration and Adjustment kp-scale window*

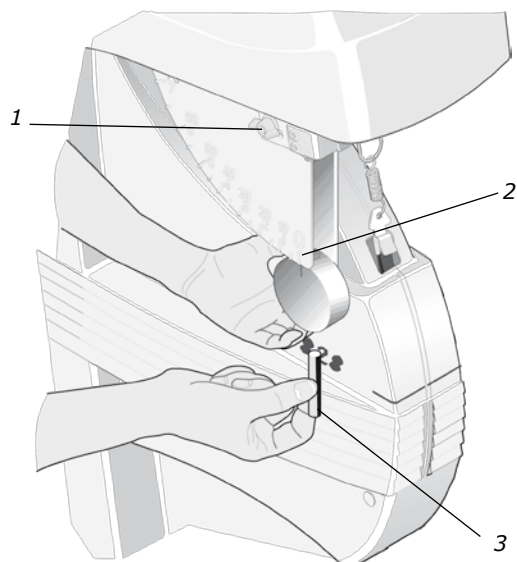

Fig: Zero adjustment

- 1) Locking nut
- 2) 0-index
- 3) Adjustment weight, pendulum

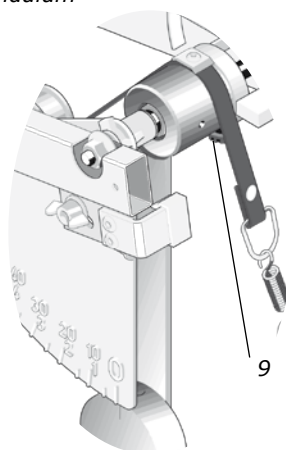

Fig: Adjustment kp-scale window
9) Lock screw for scale indicator

Calibration

All ergometers are carefully calibrated at the factory. You can check the calibration if you want to verify this, if so, proceed as follows:

Be sure that the scale board is set to zero before the weight is put on, see section "Scale - zero adjustment". Remove the brake belt from the spring. Thread the calibration weight string from below, inside the frame cover, so the string is between the flywheel and the frame cover. Hook the string into the spring (6). If the calibration is correct, it is possible to read this weight from the corresponding place on the scale board (7). See *Fig: Calibration*.

If there is a deviation, adjust the pendulum to the right position on the scale by adjusting the weight inside the pendulum (3). See *Fig: Zero adjustment*. To change the position of the adjusting weight, loosen the lock screw (8) on the back of the pendulum weight. If the pointer shows too low, the internal weight must be moved upwards. If the pointer shows too high, the adjustment weight is moved down. This process is repeated until pointer is in the correct position.

Check the calibration of the pendulum weight once a year or when needed.

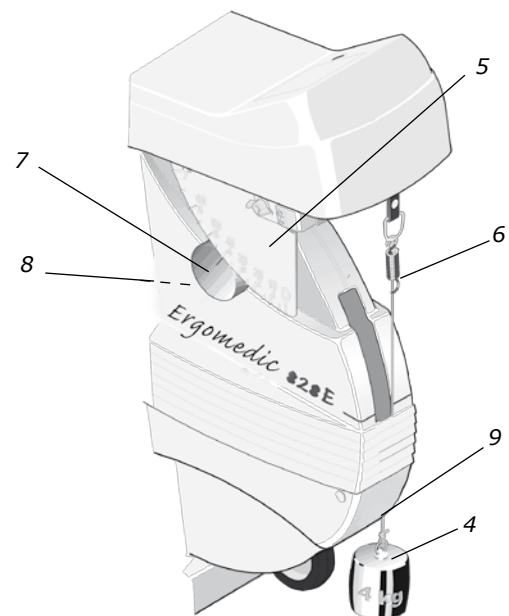

Fig: Calibration

- 4) Calibration weight, 4 kg
- 5) kp-scale
- 6) Attachment of calibration weight
- 7) Pointer at 4 kp
- 8) Screw to adjustment weight

Troubleshooting guide

Symptoms	Probable Cause / Corrective Action
There is a click noise when pedalling (increases with the weight)	<ul style="list-style-type: none"> • The pedals are not tight. Tighten them or change pedals. • The crank is loose. Check, tighten. • The base bearing is loose. Contact your dealer for service.
Scratching sound is heard when pedalling	<ul style="list-style-type: none"> • Check that the carriage block is taken off and that none of the covers is scratching.
There's a click noise and a squeak noise when pedalling	<ul style="list-style-type: none"> • Loosen the chain.
No heart rate	<ul style="list-style-type: none"> • Check that the battery is alright in the chest belt, moisten your thumbs and click on the electrodes, a low clicking sound will be heard at the battery cover, alternatively that the heart rate is displayed in the computer software. • Make sure the belt fits correctly on the test person, see <i>Fig: Placement of chest belt</i> in section "Heart Rate", and that the strap is sufficiently tightened. Moisten the electrodes, in severe cases it may be necessary to use gel alternative, one drop of dish washing liquid mixed in water. Pulse signal strength varies from person to person. Try the belt with a person known to have a good pulse wearing a chest belt. • Check for loose cables or jack if you have a plug-in receiver. Use another HR receiver (HR watch or test bike monitor) to check the chest belt. • Check that it is the correct receiver and that it is in the correct place. You should be able to read the text on the chest belt correctly oriented. • In case of problems, turn off WiFi, Bluetooth and similar on computers nearby. Although some fluorescent lamps can interfere with heart rate reception.
Any problems with the computer software	<ul style="list-style-type: none"> • Send an email to the software developer HUR labs support: software@hur.fi

Service

Note that the text about service and maintenance is universal and that all parts may not be relevant to your bike.

Warning

Make sure the voltage indicated on the appliance corresponds to the local mains voltage before making connections.

Warranty

EU countries - Private use

If you are a consumer living in the EU you will have a minimum level of protection against defects in accordance with EC Directive 1999/44/EC. In short, the directive states for that your Monark Dealer will be liable for any defects, which existed at the time of delivery. In case of defects, you will be entitled to have the defect remedied within a reasonable time, free of charge, by repair or replacement.

EU countries - Professional use

Monark Exercise products and parts are guaranteed against defects in materials and workmanship for a period of one year from the initial date of purchase of the unit. In the event of a defect in material or workmanship during that period, Monark Exercise will repair or replace the product. Monark Exercise will not, however, refund costs for labour or shipping.

Other countries

Monark Exercise products and parts are guaranteed against defects in materials and workmanship for a period of one year from the initial date of purchase of the unit. In the event of a defect in material or workmanship during that period above, Monark Exercise will repair or replace (at its option) the product. Monark Exercise will as above for labour or shipping.

Service check and Maintenance

It is important to carry out a regular service on your ergometer, to ensure it is kept in good condition.

Service action:

- We recommend isopropyl alcohol to disinfect the surface of the bike. Use a damp but not wet cloth to clean the surface you wish to disinfect.
- Always keep the bike clean and well lubricated (once a week).
- Periodically wipe the surface with a rust preventative, especially when it has been cleaned and the surface is dry. This is done to protect the chrome and zinc parts as well as the painted parts (4 times per year).
- Check now and then that both pedals are firmly tightened. If not the threading in the pedal arms will be damaged. Also check that pedal arms are firmly tightened on the crank axle, tighten if necessary. When the Ergometer is new it is important to tighten the pedals after 5 hours of pedalling (4 times per year).
- Check that the pedal crank is secure to the crank axle (4 times per year).
- Be sure that the pedals are moving smoothly, and that the pedal axle is clear of dirt and fibres (4 times per year).
- When cleaning and lubricating be sure to check that all screws and nuts are properly tightened (twice a year).
- Check that the chain is snug and there is no play in the pedal crank (twice a year).
- Check that pedals, chain and freewheel sprocket are lubricated (twice a year).
- Be sure that the brake belt does not show significant signs of wear (twice a year).
- Check that the handlebars and seat adjustment screws are lubricated (2 times per year).
- Be sure that all moving parts, crank and flywheel are working normally and that no abnormal play or sound exists. Play in bearings causes fast wearing and with that follows a highly reduced lifetime.
- Check that the flywheel is placed in the center and with plane rotation.

Batteries

If the meter is battery-operated, the batteries are in a separate package at delivery. If the storing time has been long the battery power can be too low to make the computer act correctly. Batteries must then be changed.

Flywheel bearing

The flywheel bearing is long-term greased and requires no supplementary lubrication. If a problem arises, please contact your Monark dealer.

Crank bearing

The crank bearing is greased and normally requires no supplementary lubrication. If a problem arises, please contact your Monark dealer.

Transportation

During transport the brake cord should be tightened to prevent it from falling off the flywheel.

Replacement of brake belt

To replace the brake belt remove covers if necessary. Make sure that the belt is loose.

Alt. 1: To loosen the brake belt on pendulum bikes with engine, connect power to the unit and raise the pendulum to 4 kp. Hold it there until brake belt is loose. Please note how the belt is assembled. Remove it from the bike. Attach the new brake belt and assemble the bike in reverse order.

Alt. 2: To loosen the brake cord on cycles with a weight basket set the basket to its upper position. Loosen the lock washer that is holding the cord and remove it from the tension center. Loosen or cut off the knot on the other end of the cord and then remove the whole cord from the bike. When assembling a new brake cord, first enter one end into the hole in the tension center, and tie a knot and let the knot fall into the bigger part of the hole. Lock the end of the cord with the lock washer.

Alt. 3: To loosen the brake belt on the bike remove all tension. Please note how the belt is assembled. Remove it from the bike. Attach the new brake belt and assemble the bike in reverse order.

NOTE!

When replacing the brake belt it is recommended to clean the brake surface. See "Brake belt contact surface".

Brake belt contact surface

Deposits of dirt on the brake belt and on the contact surface may cause the unit to operate unevenly and will also wear down the brake belt. The contact surface of the flywheel should be smoothed with fine sandpaper and any dust removed with a clean dry cloth.

Remove any potential covers and all workload on the brake belt and then remove it. Grind with a fine sand paper. Grinding is easier to perform if a second individual cautiously and carefully pedals the cycle.

Irregularities on the brake belt contact surface are removed by means of a fine sand paper or an abrasive cloth. Otherwise unnecessary wear on the brake belt may occur and the unit can become noisy.

Always keep the brake belt contact surface clean and dry. No lubricant should be used. We recommend replacing the brake belt when cleaning the contact surface. In regard to assembly and adjustment of the brake belt, see "Replacement of brake belt".

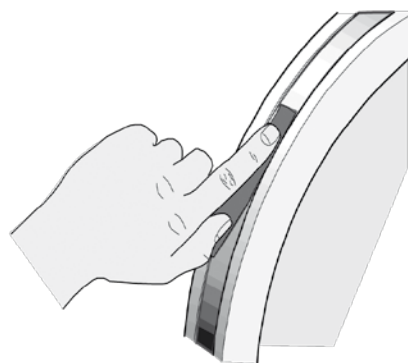

Fig: Brake belt contact surface

Chain 1/2" x 1/8"

Check the lubrication and tension of the chain at regular intervals. In the middle of its free length the chain should have a minimum play (3) of 10 mm (1/4 inch). See *Fig: Chain adjustments*. When the play in the chain is about 20 mm (3/4 inch) the chain must be tightened. Otherwise it will cause abnormal wear of the chain and sprockets. Therefore it is always recommended to keep the chain play as small as possible. Loosen the hub nut (2) on both sides and tense the chain with the chain adjuster (1) when needed.

When the chain has become so long that it can no longer be tightened with the chain adjusters it is worn out and shall be replaced with a new one.

To adjust or replace the chain, remove covers if required.

To adjust the chain the hub nuts (2) should be loosened. Loosening or tightening the nuts on the chain adjusters (1) will then move the hub and axle forward or backward. Then tighten the nuts on the hub axle again. See *Fig: Chain adjustments*.

To replace the chain, loosen the chain adjusters as much as possible. Dismantle the chain lock (6) and remove the chain. Use a pair of tongs for dismantling the chain lock. Put on a new chain and assemble the chain lock. The spring of the chain lock should be assembled with the closed end in the movement direction (5) of the chain. Use a pair of tongs for dismantling and assembling the spring (4). See *Fig: Chain replacement*.

NOTE! At assembly the flywheel has to be parallel with the centerline of the frame. Otherwise the chain and sprockets make a lot of noise and wear out rapidly.

Then assemble the removed parts as above but in reverse order.

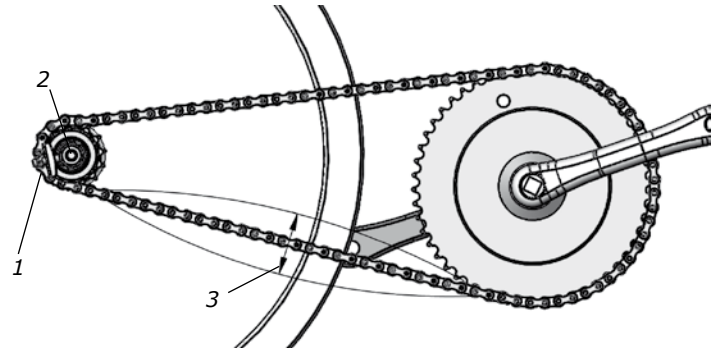

Fig: Chain adjustments
1) Chain adjuster
2) Axle nut
3) Chain play

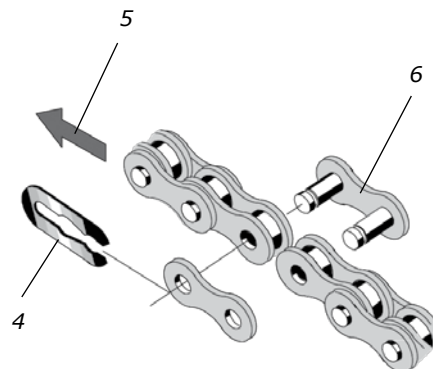

Fig: Chain replacement
4) Lock spring
5) Movement direction
6) Chain lock

Freewheel sprocket

When replacing the freewheel sprocket remove frame covers if necessary. Remove the chain according to section "Chain 1/2" x 1/8".

Loosen the axle nuts and lift off the flywheel. Remove the axle nut, washer, chain adjuster and spacer on the freewheel side. Replace sprocket-adaptor and assemble the new parts in reverse order according to the above.

NOTE! Do not tighten the axle nut completely. It must be possible to loosen the sprocket-adaptor half a turn.

The sprocket should be lubricated with a few drops of oil once a year. Tilt the cycle to make it easier for the oil to reach the bearing. See *Fig: Lubrication*.



Fig: Lubrication

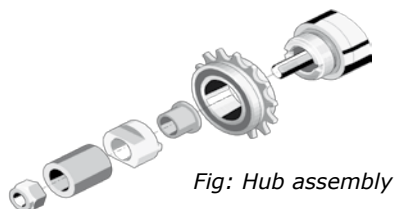
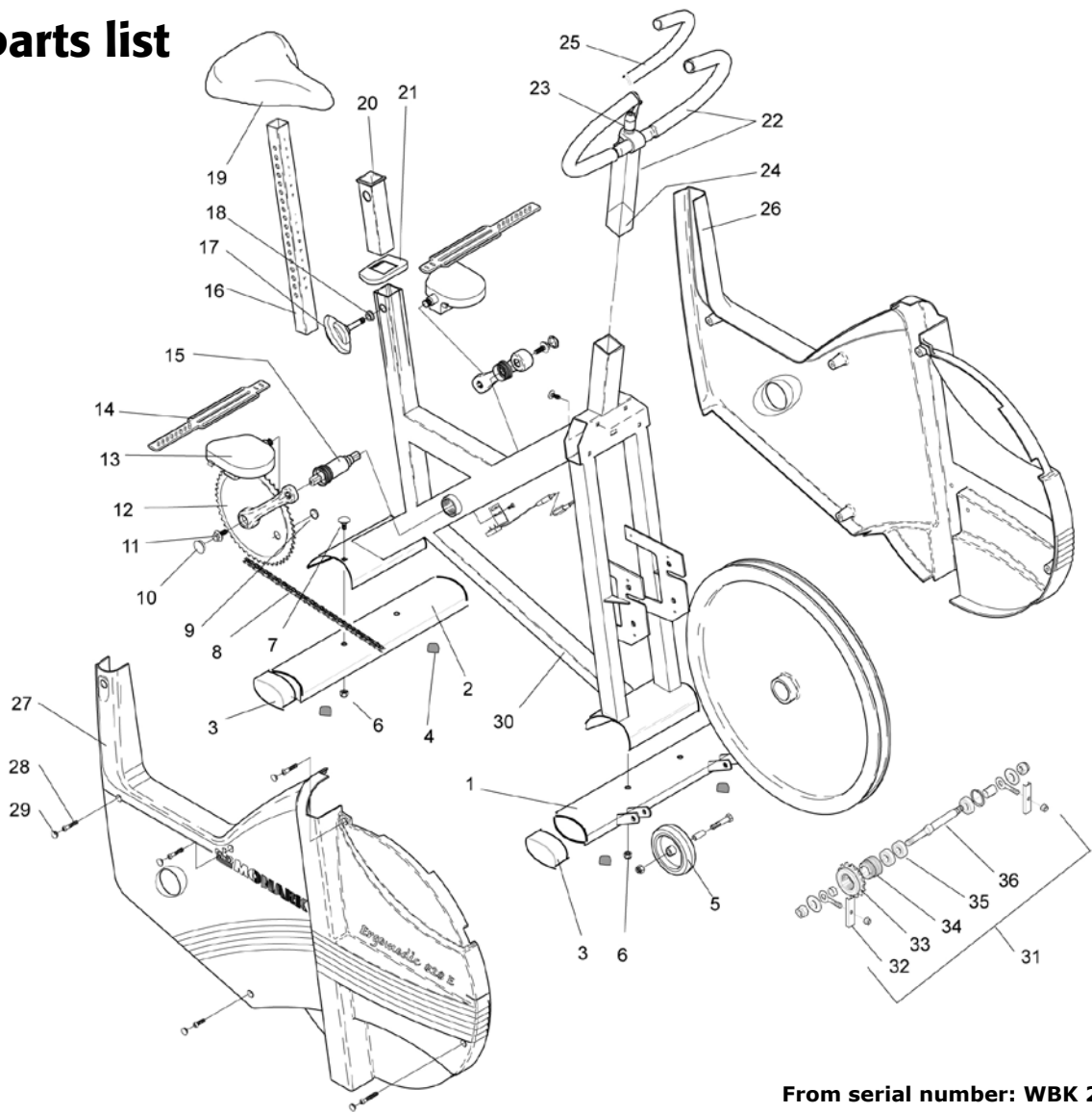

Fig: Hub assembly

Spare parts list



From serial number: WBK 265820C

Pos.	Qty.	Art. No.	Description	Pos.	Qty.	Art. No.	Description
1	1	9301-15	Support tube, front	19	1	9300-115	Bushing for saddle post
2	1	9301-16	Support tube, rear	20	1	9300-123	Top cover
3	4	9328-51	Plastic cap, blue	21	1	9300-280	Handlebar complete
4	4	9328-26	Rubber foot	22	1	9100-180	-Locking handle
5	1	9328-37	Transport wheel, compl. (pair)	23	1	9126-72	-Handgrip, blue (pair)
6	4	5845	Locking nut M8	24	1	9300-291	-Expander wedge
7	2	9300-12	Screw MVBF M8x16 mm	25	1	9300-61	Frame cover, left
8	1	9300-55	Chain 1/2 x 1/8", 116 l	26	1	9300-60	Frame cover, right
9	1	9326-164	Magnet	27	4	5673-9	Mounting screw LKT-TT 5x12mm
10	2	8523-2	Dust cover	28	10	9306-12	Dust cover
11	2	8523-115	Screw M6S 8.8 M8 x 20 FZB	29	1	9301-5	Frame
12	1	9300-430	Steel crank set, complete	30	1	9300-24	Wheel suspension complete set
13	1	9300-220	Pedal (pair)	31	1	9000-12	-Chain adjuster (pair)
14	1	9300-207	Pedal strap, (pair)	32	1	9106-13	-Sprocket
15	1	8966-175	BB cartridge bearing	33	1	9106-14	-Connection
16	1	9300-138	Saddle post	34	3	19001-6	-Bearing 6001-2z
17	1	9300-133	Locking knob, complete	35	1	9300-18	-Axle
	1	9300-122	-Locking knob	36	1	9300-17	-Bush, 23 mm
	1	9300-134	-Pressure washer		1	9339-98	Chest belt
18	1	4994-5	Saddle		1	9000-211	Calibration weight 4 kg
	1	9300-114	-Saddle clamp				

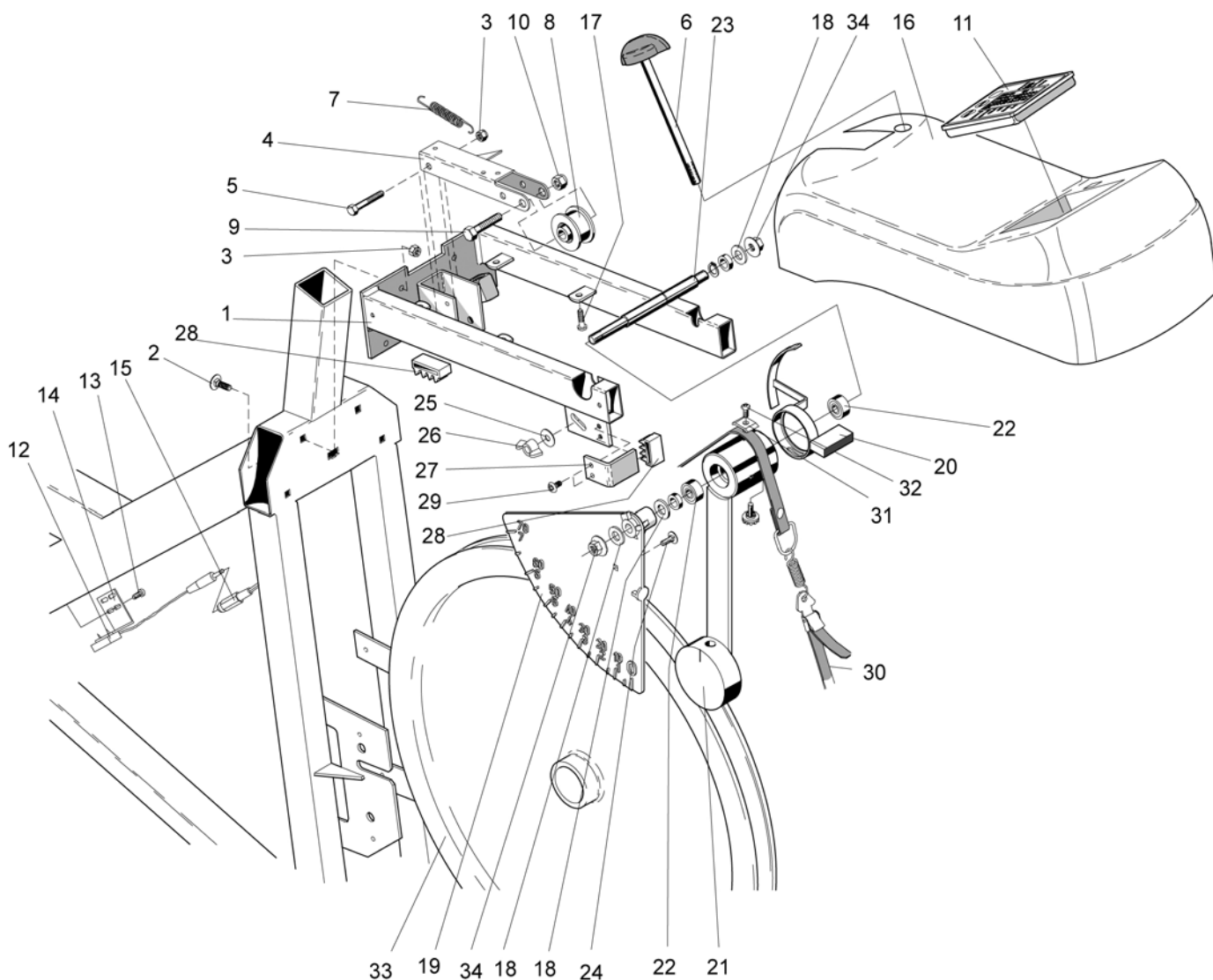

From serial number: WBK 265820C

Pos.	Qty.	Art. No.	Description	Pos.	Qty.	Art. No.	Description
1	1	9300-30	Frame for equipment	18	3	5866	Washer
2	4	9300-21	Screw MVBF 6x16 mm		1	9300-36	Meter panel, complete
	4	5863	Washer	19	1	9339-100	-Meter panel
3	5	5843-9	Nut M6	20	2	9000-17	-Spacer
4	1	9300-22	Tension lever	21	1	9300-93	- Scale 7 kp
5	1	14333-9	Screw M6x45 mm	22	1	9000-103	-Screw
6	1	9300-25	Tension screw M8, complete	23	1	9300-88	-Weight lever
7	1	9100-20	Spring	24	2	19001-6	-Bearing 6001-2z
8	1	9100-26	Tension cylinder, complete	25	1	9300-86	-Axle
9	1	14358	Screw M8x40 mm	26	1	9300-87	-Lock ring SgA 12
10	1	5844	Locking nut M8	27	1	9339-21	Screw
11	1	9300-170	Meter	28	1	5862	Washer
	2	2151	Battery AA size	29	1	9000-102	Wing nut
12	1	9326-162	Crank sensor with cable	30	1	9300-94	Stop
	2	9103-40	Screw for crank sensor	31	2	9300-99	Plastic stop
13	1	9126-75	Screw RXS B8 x 9.5 FZB	32	1	5671-9	Screw M5 x 10 mm
14	1	9326-166	Holder for sensor	33	1	9103-62	Brake belt, complete
15	1	9326-263	Cable 620 mm	34	1	9300-92	Washer
	5	9300-66	Holder for cable	35	1	5675-9	Mounting screw
16	1	9300-142	Instrument cover	36	1	9300-3	Flywheel
17	4	5768	Mounting screw for cover	37	2	5799	Nut



Version 1311
Art. No: 7950-296

